

normet

Normet Oy
Ahmolantie 6
FI-74510 IISALMI, FINLAND
Tel +358 (0) 17 83 241
Fax +358 (0) 17 823 606
info@normet.fi

Himec 9910 B Rex

TI 100019245
DATE 13.06.2014
PAGE 1 / 6

Single boom extendable platform lifter

MAIN DIMENSIONS

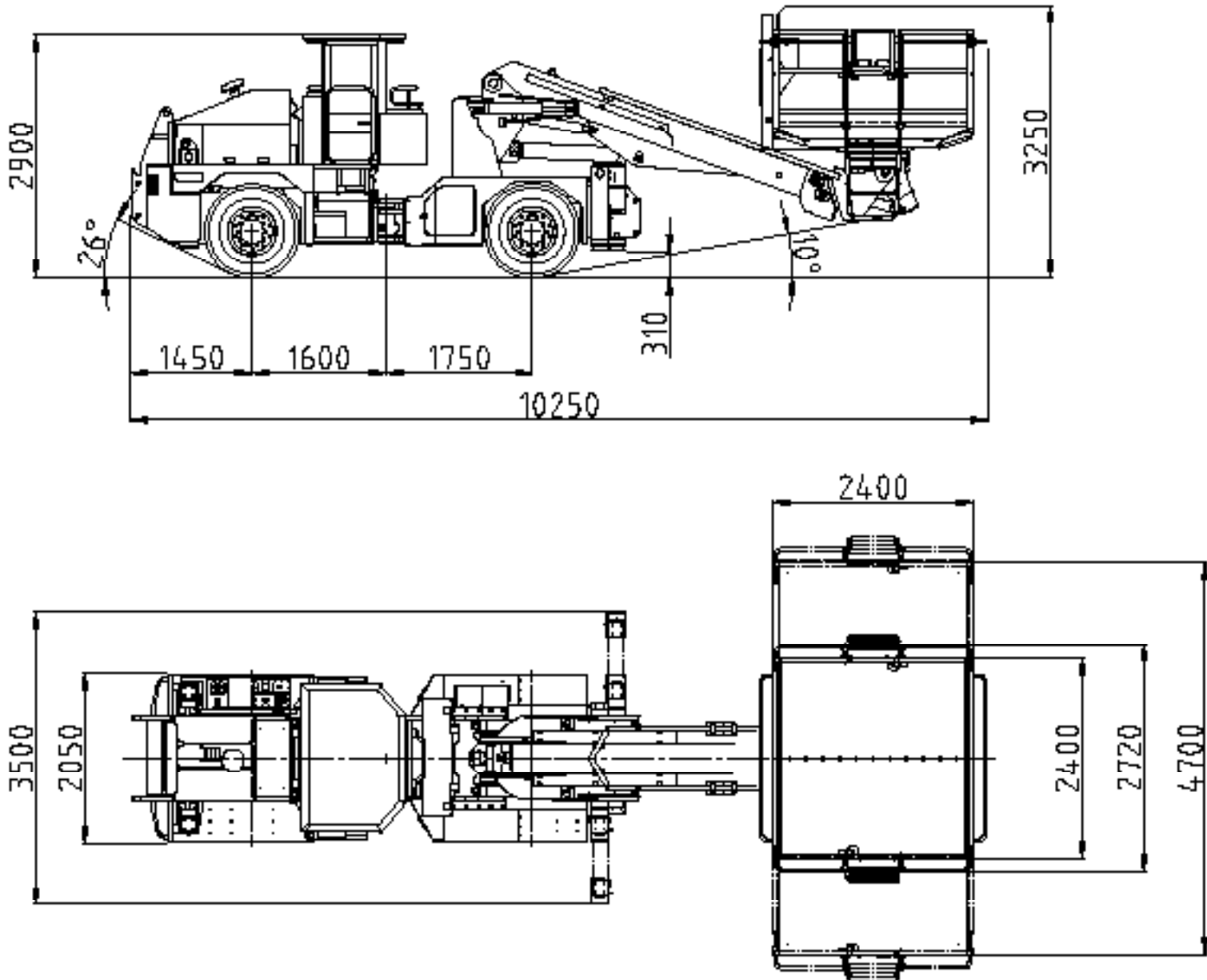

REA

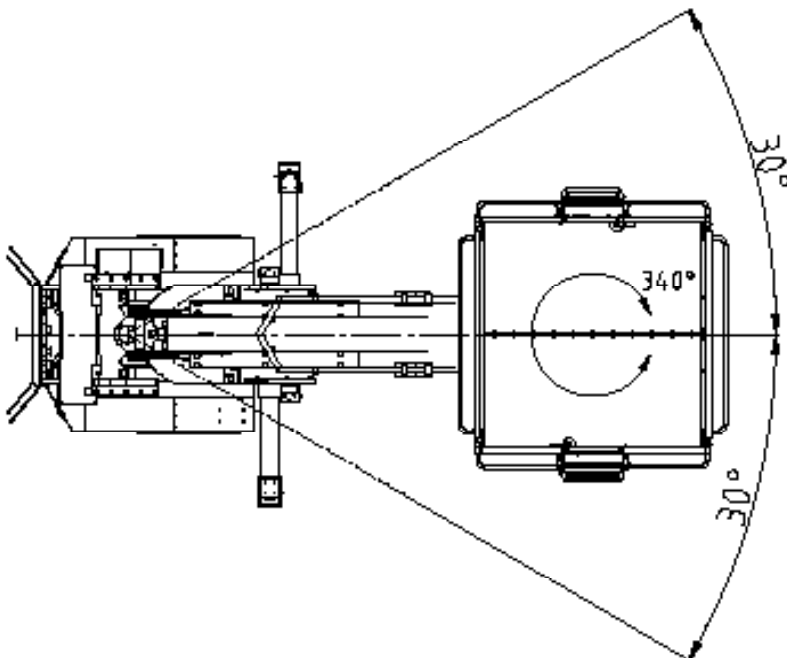
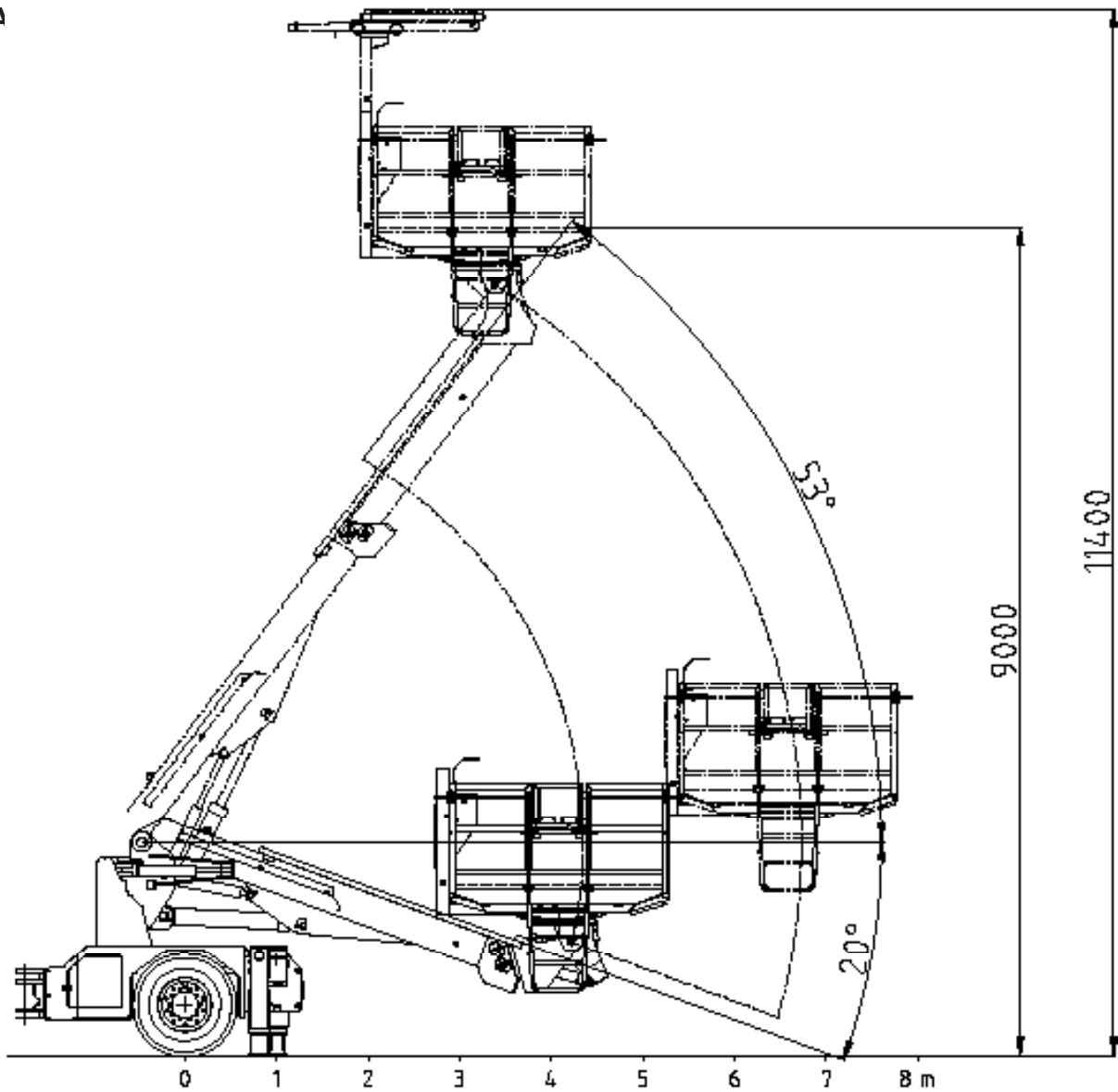

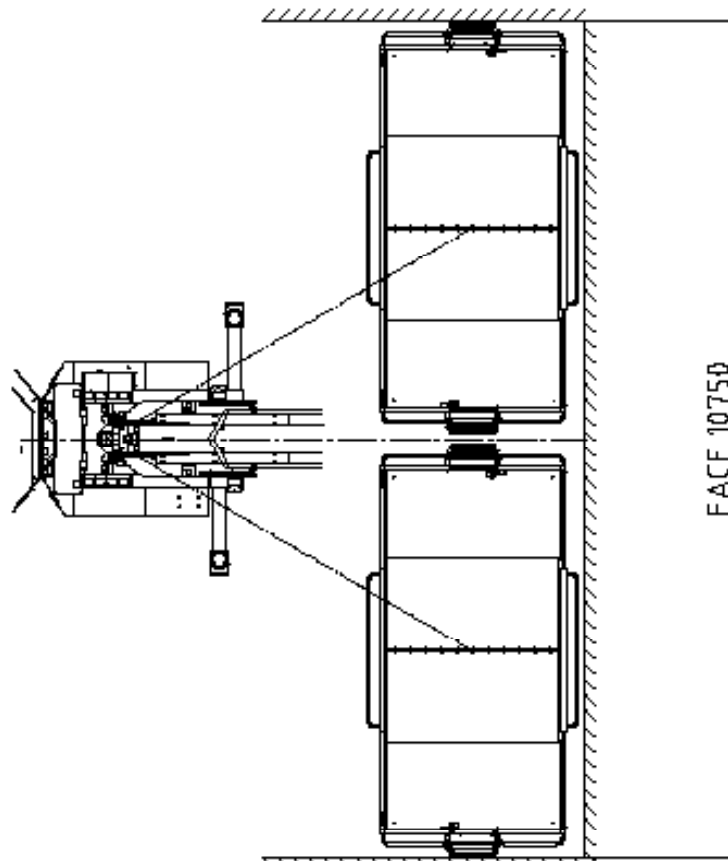
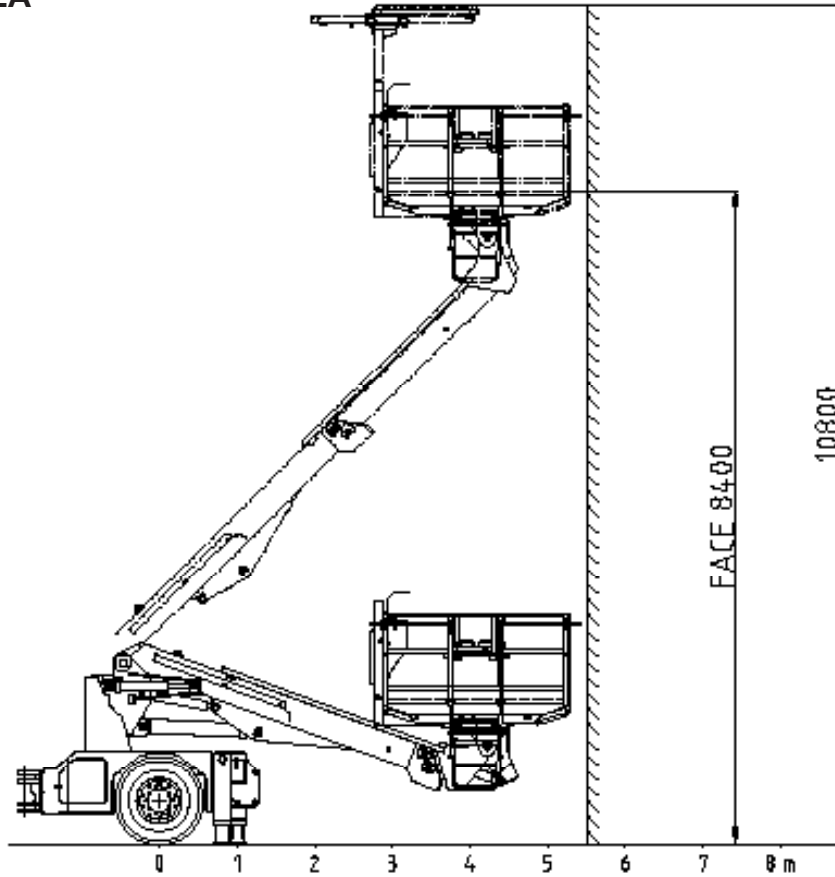
FACE REACH AREA

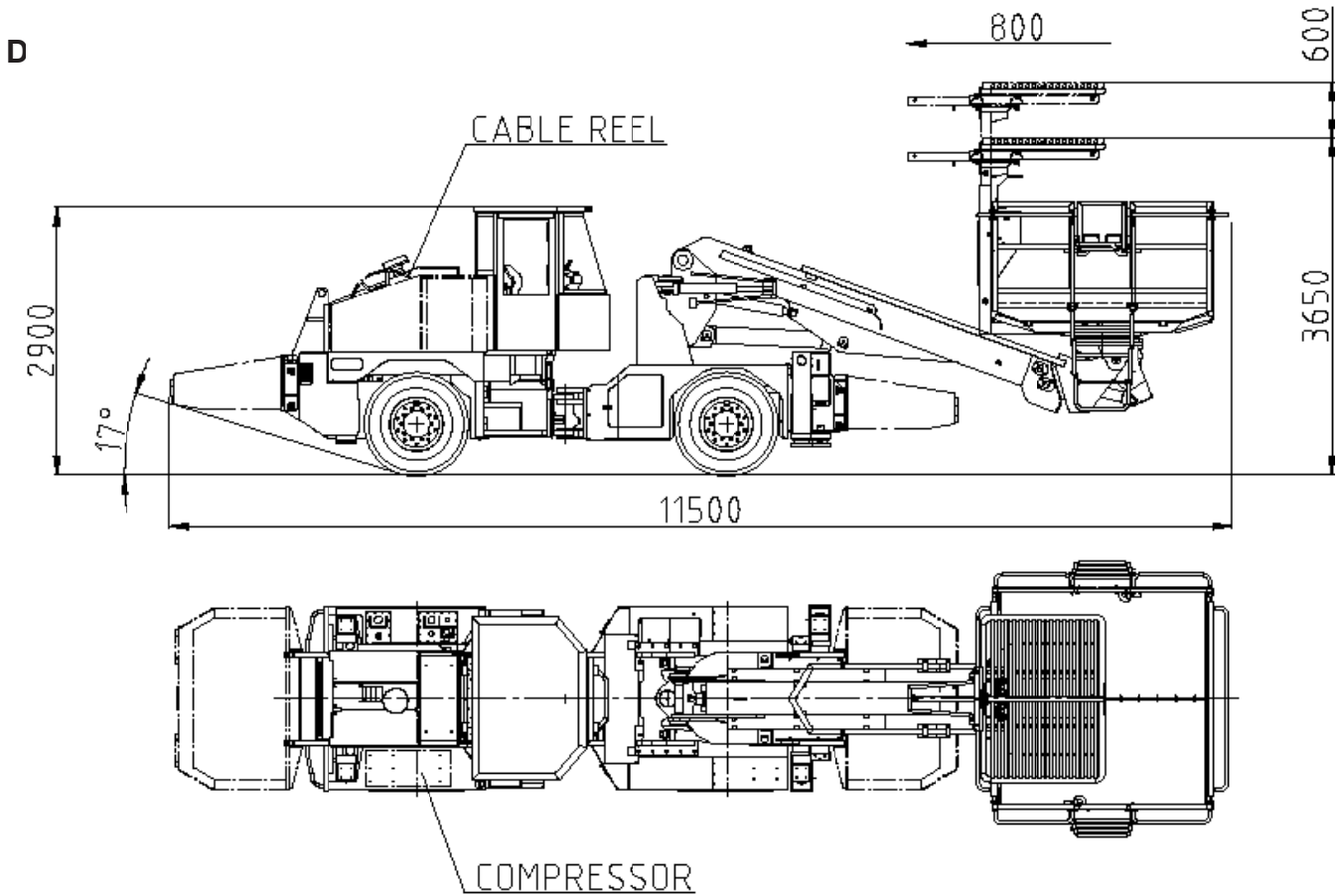
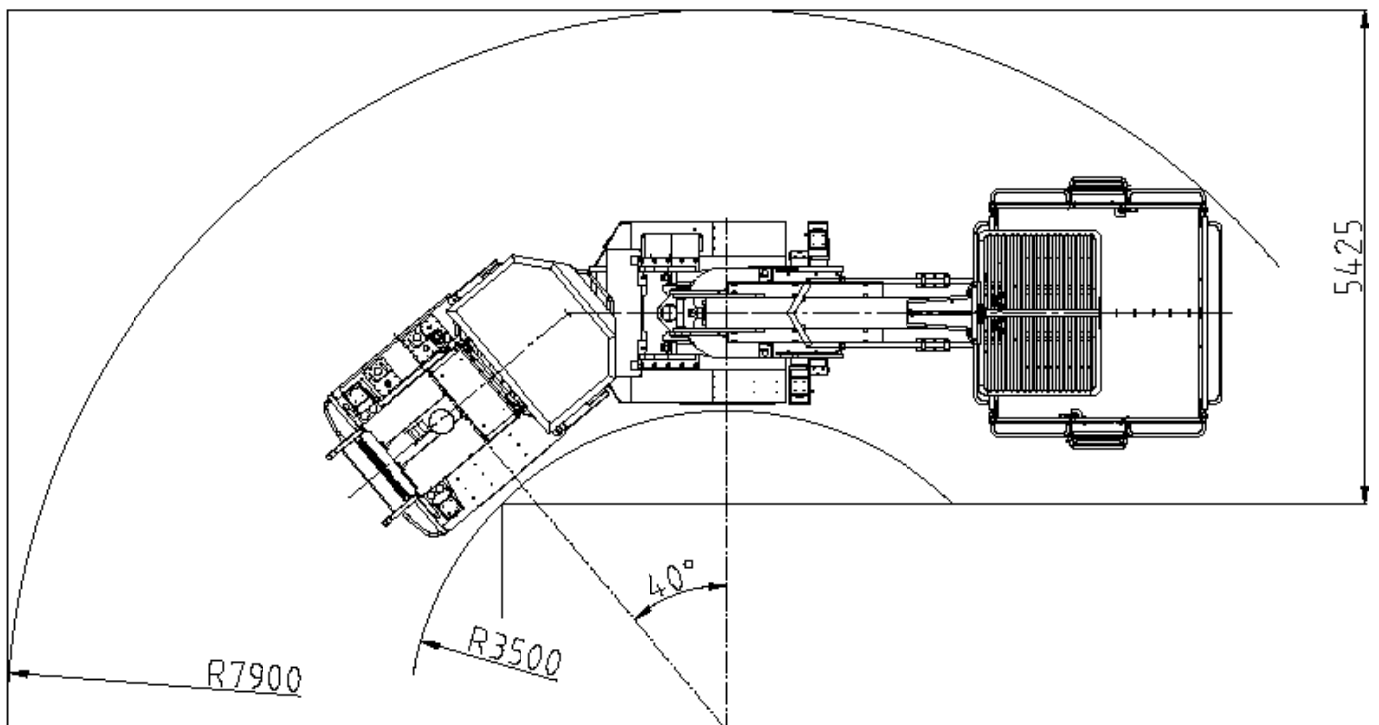
**TURNING RADIUS**

HIMEC 9910 B REX

is a self propelled diesel driven 1-boom lifting unit suitable for charging of explosives, lifting and installing works in tunnelling.

DIMENSIONS

Length	10250 mm
Width	2050/3500 mm
Height	2900 mm
Wheel base	3350 mm
Ground clearance	310 mm
Outer turning radius	7900 mm
Inner turning radius	3500 mm
Weight, operating	20200 kg

NORMET SUPERBOOM NSB900

is a heavy duty multipurpose boom suitable for charging, scaling, spraying of concrete, bolting and installing works. Different work platforms and net & roof support installing equipment are available. Boom is controlled from the platform and from the carrier.

Basket can be equipped with FOPS tested safety canopy (EN ISO 3449).

Boom lift	- 20° ... + 53°
Boom slew	+/- 30°

WORKING PLATFORM REX

is a hydraulically extensible platform with patterned plate working surface, safety railings and boom and platform controls on board. Automatic horizontal holding system and platform rotating provide good working flexibility and applicability for most various lifting works.

Working reach - roof	11,4 m
Working reach - face	10,8 m
Platform rotation	340°
Platform size	
- base	2,40 m x 2,40 m
- extended	2,40 m x 4,70 m
Lifting capacity	1000 kg
Lifting capacity with safety roof	2 persons + 550 kg = 710 kg

WORKING LIGHTS

2 x 70 W on the work platform
4 x 70 W on the carrier

SUPPORT LEGS

One pair in front and one pair at rear, hydraulically operated, front pair with lateral extensions.

SAFETY CANOPY

over the drivers seat fulfills the European safety regulations. Driver's cabin is FOPS/ROPS tested.

CARRIER NC 98

is specially designed for underground use. Diesel engine with hydro-dynamic transmission and 4-wheel drive gives max. speed of 25 km/h. Fully enclosed multidisc 2-circuit brakes and parking and emergency brake make operating reliable and safe in the harsh underground conditions.

Diesel engine	96 kW
Max. tractive effort	85 kN
Max. speed	25 km/h

OPTIONAL EQUIPMENT

Enclosed cabin for NC98 (ROPS/FOPS)
Particle filter for Deutz TCD 2012 L04 96kW
Xenon working lights on cabin (2 + 2)
LED driving lights (4 + 2 pcs)
LED working lights on cabin (2 + 2 pcs)

ADDITIONAL EQUIPMENT

Electro hydraulic drive 15kW:

- 400 V / 50 Hz with 50 m cable and hydr. reel
- 440 V / 50 Hz with 50 m cable and hydr. reel
- 690 V / 50 Hz with 50 m cable and hydr. reel
- 1000 V / 50 Hz with 50 m cable and hydr. reel

Hydraulic driven high pressure washer 180 bar / 30 L
CD/Radio system (for enclosed cabin)
Cabin heating (for enclosed cabin)
Air conditioning (for enclosed cabin)
Fogmaker extinguishing system (manual)
Fogmaker extinguishing system (automatic)
Ansul extinguishing system (manual)
Ansul extinguishing system (automatic)
Tempus manually actuated (Non CE)
Lubrication system for carrier and NSB boom (Lincoln)
Hydraulically driven compressor 5 m3/min
Sliding safety roof for REX basket (FOPS)
1 extra hand held fire extinguisher (12 kg)
1 extra rotating beacon amber
1 extra rotating beacon red
1 extra rotating beacon blue
1 extra strobe light white
Toolbox and maintenance tools
2 pcs wheel chocks with brackets
Spare wheel
Rack for equipment and tools
Text labels in:
Fin / Por / GB / Swe / Rus / Nor / Ger / Fra / Spa / Ita

LTC SERVICES**SPARE PARTS**

Spare parts package A: Available for 1000 h of use*.
Include periodical service, most common wearing parts and most critical safety parts.

Spare parts package B: Available for 3000 h of use*.
Include periodical service, most common wearing parts and most critical safety parts.

* Recommendations are based on average hours - can vary a lot depending on work site conditions.

TRAINING SERVICES

Available before delivery, at start up and after delivery

Product training:

Operation and Maintenance
NorSmart
Foundation of electrics, hydraulics and mechanics
Audit

Process training:

Concrete spraying
Charging
Process audit

AUDIT SERVICES

To improve performance of the machines
To improve the performance of your processes
To help improve the quality of maintenance operations

SERVICE CONTRACTS

Spare parts supply programmes
Scheduled inspection programmes
Supervision programmes
Periodic maintenance programmes
Machine usage programmes

LINK ONE

Link One electronic spare part manuals

WARRANTY SERVICES

Extended warranty